

ALPS ELECTRIC CO., LTD.

Green Procurement Standards



Friendly to people, friendly to nature.

Enforced: **December 1, 2018**

Revised: **November 1, 2018**

Established: July 26, 2002

Alps Electric Co., Ltd.

CONTENTS

1. INTRODUCTION	----- P 3
2. ALPS Environmental Protection Charter	----- P 3
3. ALPS Green Procurement Outline	----- P 4
3.1. ALPS Environmental Evaluation Standard on Companies	----- P 6
3.2. ALPS Parts Evaluation Standard	----- P 9
3.3. Procedure for Environmentally Hazardous Substance Survey	----- P 13

1. INTRODUCTION

As you know, for these years, protection of global environment has been treated as an issue of the whole world. This is the problem that we, makers, have to work on as the most important subject of our company management.

Now, ALPS established Environmental Protection Charter in 1994. Since then, we have promoted global ecology movement with a slogan, “friendly to people, friendly to nature.” Starting with an acquisition of certification ISO14001 for standard for environmental management system in 1996, every productive point in Japan and overseas obtains it currently. Moreover, we have been working on saving energy, recycling, and other policies, and we are acting to reduce environmental load at all the situations of development, production, and sales.

Even if we are promoting these actions, however, there is the limitation with the actions only in our company. Specifically, the materials which we buy from each supplier need to be “environment-friendly.”

By the reason, our company raised the common purchase policy, “We buy environment-friendly materials and parts from the suppliers that understand protection of global environment enough and manage their own companies”.

Concretely, we have established a new policy, “Supplier Assessment Prescript” in July, 2002, and we have started to purchase materials and parts along the Standards from this September. We really hope to have your kind corporation.

2. The Alps Group Environmental Charter

—Basic Philosophy—

ALPS, as a member of the global community, is committed to protecting the beauty of nature and to safeguarding our precious resources through the use of technologically advanced business practices and the efforts of its employees, in order to promote sustainable development.

—Action Program—

Placing priority on environmental protection, we at ALPS will:

1. Develop products in light of environmental concerns
2. Engage in environmentally friendly production and sales
3. Conserve our natural resources
4. Reduce or eliminate waste
5. Increase recycling activities

3. ALPS Green Procurement Outline

1. General Rules

1) Purpose

This Supplier Assessment is established to abide our basic idea “ALPS, as a member of the global community, is committed to protecting the beauty of nature and to safeguarding our precious resources through the use of the technologically advanced business practices and the efforts of its employees in order to promote sustainable development.” That is, it shows the guide to purchase environment-friendly materials from prior suppliers managed with sufficient understanding of global ecology.

2) Application

This assessment outline shall apply to procurement activities of different kinds of materials at ALPS and its affiliated companies. The different kinds of materials referred to herein shall mean raw materials, parts (generally purchased items and supplier processed parts), packaging materials, and auxiliary agents.

2. Selection Standards on Green Procurement

1) About the selection standards

Green Procurement of every kind of material at our company is on the two selection standards below.

1 - Selection standards of suppliers (Environmental Evaluation on Companies)

---- Evaluation of ecology movement

2 - Selection standards of purchase (Parts Evaluation) ---- Evaluation of each purchase

2) Selection standards of suppliers (Environmental Evaluation on Companies)

When we select a supplier, we have considered quality, delivery, cost, service, ability of technical development, etc. Now we add the supplier’s working on environmental protection activities to our evaluating standards.

3) Criteria for selecting purchased materials (Parts Evaluation)

In selecting different kinds of materials to be purchased, materials meeting the criteria in the “List of Environmentally Hazardous Substance Control Standard” (Appendix 4) will be selected preferentially, in addition to considering quality requirement, function and cost.

3. Application of Supplier Assessment

Each supplier is asked the green procurement system for the registration of manufacturing base information when having dealings with our company. ALPS will allocate and inform each supplier of a company code, a user ID, and a password.

Green procurement system (GreenAXIS CR) URL of the system is as follows.

URL : <http://green.alps.com/public/>

1) Registration of manufacturing base : Each supplier is supposed to investigate manufacturing bases

where the supplier manufactures parts and/or materials for ALPS. Environmental Evaluation on Companies

For the activity on ecology movement of supplier, please search the following content.

(1) New assessment

When the productive point is changed or added, or new supplier is generated, please search it before starting transaction.

(2) Periodical assessment

a) Please update the registration data (acquisition state of certification of ISO etc.) of green procurement system periodically (once a year).

b) The suppliers are selected by operation sites (factories) and overseas production affiliates, and the research shall be implemented periodically (once a year or more) using the "Environment Managing Company (Supplier) Self-assessment Sheet" (Appendix 2).

(3) Interim assessment

When the assessment method is changed or the system of supplier is changed or for other cases (when an accident is generated, when the response to customer is necessary etc.), the research shall be implemented according to the request from operation sites (factories) and overseas production affiliates.

For the assessment result, please input the ISO certification state, rank as assessment result and self-assessment sheet in green procurement system.

3) Parts evaluation

For the activity relevant to environmental conservation of purchased resources, please search the following content.

(1) Research will be implemented as occasion demands. Each supplier shall investigate the analysis data by the method according to "Analytical Method" (Appendix 6).

(2) The evaluation results investigated by using "Collective Registration Tool"(Appendix 7) is collected in electronic data format (Excel data). And the printed research tables shall be sent as a proof of input.

4) Revision of this outline

This Green Procurement Outline will be revised as required according to changes in social situations, and the trend of legal regulations.

3.1. ALPS Environmental Evaluation Standard on Companies

1. Environmental Evaluation on Companies

We raised the purchase policy, “We buy environment-friendly materials and parts from the suppliers that understand protection of global environment enough and manage their own companies”, and established “Supplier Assessment Prescript.”

This revised standards make in accordance with Japanese Industrial Standard (JIS) "JIS Z 7201:2012 Management of Chemical Substances in Products - Principles and Guidelines".

When the transaction of new supplier is started or when the productive point is changed or added, please implement the research before transaction is started, and for the periodical assessment (once a year) and interim assessment, please implement the research according to the request from Division Headquarters in Japan and overseas affiliate. We hope the transaction after cutting in the standard of this environment company assessment.

2. Target range of assessment

- 1) Each supplier shall evaluate its environmental protection activities at manufacturing bases for mass-produced parts (raw materials, purchased parts, processed parts, packaging materials, and auxiliary materials).
- 2) We hope your reply will be not of a company but of each productive point of material delivered to our company.
- 3) If your company is a trading company or an agency, the evaluation object will be the final factory (manufacturing base), rather than your company.

3. Procedure of Evaluation

- 1) “Green Procurement Standards” and “Self-evaluation sheet for supplier of environmental management” (hereinafter Self-assessment Sheet) will be distributed to you.
- 2) You will please enter Self-assessment Sheet and do your self-assessment.
- 3) As a check of management system on environmental conservation activities, please clarify the acquisition state of following certifications in Self-assessment Sheet.
 - (1) Date of acquisition of ISO14001 (date of update), certification authority, certification No.
 - (2) Date of acquisition of ISO9001 (date of update), certification authority, certification No.
 - (3) Date of acquisition of **IATF16949** (date of update), certification authority, certification No.
- 4) Please clarify the management frame in Self-assessment Sheet and select appropriate (3 points), to quasi-compliant (1 point), not appropriate (0 point) or not relevant for the item relevant to that management frame.

If you select it, the calculation is implemented on sheet, and the score is displayed as 100 point corresponding value.

In the "evidence" column, please enter the objectively checked fact that will be the evidence with the document name etc. If there is an elsewhere item, enter the reason within possible range for

each item.

* When you attach the copy of document as objectively checked evidence, please add the reference No. to that document and enter the No. in "answer" column.

For detailed entry method, please refer to the Explanation for Self-assessment Sheet and Creation Procedure (Appendix 1).

<Evaluation Results and ALPS Policies>

* The table is changed (insert a line between ranks A and B / the content is added

Rank	New supplier determination criteria	Criteria to determine business continuation into next year
Rank A: Total score of 100 No incompatibility	Business will be started.	Business will continue into next year.
Rank B: Total score of 80-99 No incompatibility	Business will be started. The improvement plan should be created and the improvement result and the evidence should be reported.	Business will continue into next year. The improvement plan should be created and the improvement result and the evidence should be reported.
Rank C: Total score of 50-79 No incompatibility	Business starts on conditions. Condition: Improvement plan shall be created and the result of improvement / evidence shall be reported.	Business continues on conditions. Condition: Improvement plan shall be created and the result of improvement / evidence shall be reported.
Rank D: Total score of 49 or less Or, there is an incompatibility (including no submittal of sheet)	No business will result in principle. If prospect of improvement can be determined, business will start.	If this rank continues, the business may be suspended.

- 5) After entering the Self-assessment Sheet, send it to your window person, who make a request to fill it, please. After Alps has verified the evaluation results, Alps will register it to the system.
- 6) If the score of self-assessment is less than 100 points, please fill in the field of improvement plan of the self- assessment sheet.
Please submit the result of improvement and evidence after the improvement.
- 7) If the score of self-assessment is 80 points or more, we can start the transaction. When the assessment method is changed, we may request the assessment in new assessment method, so please cooperate with us in that case.
- 8) If the suppliers newly obtain, lose the acquisition or update the ISO14001, ISO9001 and **IATF16949** after replying the research, please make an input in the green procurement system and contact our window office.
- 9) If you may wish to newly register or make a change to a manufacturing base, please submit the

above self-assessment, and at the same time, obtain an approval from our company.

4. Details of Self-evaluation Procedure

Please use the "Explanation for Self-assessment Sheet and Creation Procedure" (Appendix 1) and "Self-evaluation sheet for supplier of environmental management " (Appendix 2). How you are working on your environmental protection will be self-assessed in the form of answering the questions from us.

3.2. ALPS Parts Evaluation Standard

1. Purpose

Our company is producing effectively and efficiently by using the beneficial properties of chemical substances. On the other hand, many of those chemical substances become harmful to the environment and people, when we make a mistake on the ways of using and controlling them. So it is an important subject for our producing activities to use the beneficial properties of those chemical substances excluding their harmful effects.

As the responsibility of a business entity under such a background, it is intended to provide safe products with less environmental load and reduce the environmental load associated with the production activities by establishing environmentally hazardous substance control standard independent to our company transcending the legal regulations.

2. Scope of Application

- 1) This standard shall apply to raw materials, parts (generally purchased items, and supplier processed parts), packaging materials, and auxiliary materials (collectively "Objects"), as well as parts used in ALPS manufacturing processes and packaging materials for Objects. If requested by customers, the standard shall apply also to facilities, jigs and tools, and furnishings.
- 2) This standard shall not apply to chemical substances used by suppliers in their manufacturing processes, except for ozone-layer depleting substances. However, the standard shall apply to chemical substances that remain in materials purchased by our company.
- 3) In principle, those contained intentionally are the object of the standard. However, if existing as impurities, those set with tolerances shall be applied with the standard.
- 4) The period of time of use prohibition is established as the company standard, which may vary by customers. For such a case, the period shall be agreed depending on individual products.

3. Definition of Terminologies

- 1) Environmentally hazardous substances: Chemical substances which may give harmful effects to ecology including global environment and human being, such that are specified by our company. ("List of Environmentally Hazardous Substance (Group)"(Appendix 3))
- 2) Homogeneous material: A homogeneous material is one that cannot be mechanically disjointed into different materials. For this purpose, the term "homogeneous" means of "uniform composition throughout."
Examples of "homogeneous materials" are individual types of: plastics, ceramics, glass, metals, alloys, paper, board, resins and coatings.- The term "mechanically disjointed" means that the materials can, in principle, be separated by mechanical actions such as: unscrewing, cutting, crushing, grinding and abrasive processes.
- 3) Intentional inclusion: State of being added in order to provide the object material with the specified performance.

- 4) Impurities: Unreacted residues existing in the applicable substances, residues impossible of technical removal in the refining processes, and nature originated substances contained unintentionally. It should have the same meaning as "not intentionally contained".
- 5) Inclusion tolerance: Abbreviated to "tolerance". Measures of inclusion which may give influence as the environmentally hazardous substance. Two types of expressions may be used for environmentally hazardous substances in homogeneous materials: "specified content ratio", and "unintended inclusion". Called ""threshold"" value professionally.
In case of unintended inclusion and inclusion ratio stipulate clearly is written in inclusion tolerance, inclusion ratio is mean for impurities in this standard.
- 6) Plastics: It collectively refers to a high-polymer material with certain rigidity. It also means a molded article made of various synthetic resins, including thermosetting resin and thermoplastic resin. Hardened adhesive agents are included in this category.
- 7) Synthetic rubber (elastomer): It refers to a molded article with elasticity made of various synthetic resins. It can be classified roughly into two types; general rubber with cross-linkage (thermosetting elastomer) and thermoplastic elastomer with thermoplasticity.
(Representative examples of cross-linked rubber)
Rubber contact made of silicone rubber, O-ring made of NBR, etc.
- 8) Chemically formed product: Aqueous solution having no particular shape, solid or powder such as detergent, adhesive, lubricant, mold release compound, abrasive, and wax, the chemical substance itself, or being mixture of chemical substances.
- 9) Article : The "article" refers to an object to which during manufacture is given a particular shape, appearance or design that determines the function of the end-use to a degree larger than what is performed by the chemical composition. (example: procurement parts, molding parts)
- 10) Environmentally Hazardous Substance Inclusion Report (serving also as guarantee on non-use of substances prohibited of use): This is a document peculiar to ALPS; it is intended to be used to obtain information about inclusion of environmentally hazardous substances. The report can be created by entering environmentally hazardous substances into an Excel file called "Collective Registration tool (hereafter, it is referred as Registration tool)" and printing it out. This document may be used as "Non-use guarantee letter".
- 11) Safety Data Sheet (SDS): Documents for suppliers to provide such items of information as danger and noxiousness, applicable legal regulations, and cautions for handling for chemical substances and mixtures having no particular shape including chemically formed products and raw materials. Information on the previously described chemically formed products and raw materials should be submitted.
- 12) Component table: A table showing names and ratios of chemical substances composing a particular member, used as the verification material for non-use of substances prohibited of use. The following document is treated as a Component table. However, it is limited "Electric".

[In case of Chemically formed product]

SDS and Information Sheet on the Content of Certain Chemical Substances

SDS and JAMP MSDSplus or chemSHERPA

[In case of Article]

JAMP AIS or chemSHERPA

- 13) JAMP MSDSplus: A basic information transmission sheet for transmitting the information of chemical substance contained in products recommended by Joint Article Management Promotion-consortium (hereafter, JAMP) in which the information such as "name of regulation etc." for the element to be managed, which is contained in material and dosage, "contained or not contained", "substance name", "CAS number", "density" of substance to be managed is described. It is used as a supplement of SDS and usually transmitted as a set with SDS.
- 14) JAMP AIS: A basic information transmission sheet for transmitting the information of chemical substance contained in products recommended by JAMP in which the information such as "mass", "position", "material" of molded article and "whether the substance corresponding to the regulation to be managed is contained, substance name, contained amount and density for each molded article" is described
- 15) chemSHERPA: Generic name given to the new scheme for communicating information on chemical substances in products. <https://chemsherpa.net/>
- 16) GADSL : GADSL is to become the company specific list for declaration of parts composition within the automotive industry. The information is applicable to the use of these parts or materials in the production of a vehicle up to its usage and relevant to the vehicle's re-use or waste disposal.

4. Management of Acquisition of Documents Required for Parts Evaluation

With regard to materials purchased by our company as regulated in the above scope of application, such documents shall be submitted as the environmentally hazardous substance inclusion report, and any one or more of analytical data, component table or SDS, JAMP MSDSplus or chemSHERPA otherwise JAMPS AIS or chemSHERPA as the verification data thereon, according to the types of respective object goods and the types of the chemical substances. .

The verification data to be presented will be notified by ALPS in each request for survey.

“The Environmentally Hazardous Substance Inclusion Report (serving also as guarantee on non-use of substances prohibited of use)” (Appendix 8) acts also as the guarantee letter on non-use of substances prohibited of use. The documents to guarantee non-inclusion of substances prohibited of use shall be valid as long as there is no change in the relevant facts. Please note, however, that ALPS may individually set the validity of the documents according to customer requirements.

For packaging materials used for packing ALPS products, please submit verification data for all environmentally hazardous substances designated herein. For packaging materials used for packing parts to be delivered to ALPS, please submit verification data for four heavy metals: lead, cadmium, hexavalent chromium, and mercury.

5. Chemical Substance Management Standards

5.1 Management Level

The environmentally hazardous substances have their risk to environment vary according to applications and use methods. Therefore, even the same substance may have to be divided into two categories: one whose application must be regulated strictly, and one whose risk can be reduced considerably by controlling it adequately depending on application. In addition, there may be cases where no adequate substitute technologies are available, and where the risk caused by not using the substances is greater than that in using them. Based on the above assumptions, the management levels composed of the follow two are established so that adequate management can be put into practice. (Refer to “List of Environmentally Hazardous Substance Control Standard”(Appendix 4))

1) Prohibited substances

Substance whose risk to environment is determined serious from legal reasons whatever they may be, or precedents in the past.

Please report prohibited substances when you intentionally contain it without exceeding the threshold.

This means prohibition of use as of the present time, and its use and inclusion are not tolerated within the scope of application thereof. No exceptions are allowed particularly on the substance to which legal regulation is used as the base. In order for you to guarantee that prohibited substances are not contained in the purchased materials, you will please submit the analytical data, component tables, or non-use guarantee letter and so on.

2) Controlled substances

Substances with which it is intended to actualize them being environmentally hazardous substances at the present time to carry out appropriate control as the prime object, and which have a possibility of being ranked up to the prohibited substances according to the future findings, and trend in the social environment and legal regulations. Substances for uses specified of exception for application according to laws and regulations inside and outside the country shall be treated as the controlled substances.

It is necessary to report when the material is contained. At this time, the material that impurities etc. do not intentionally contain is reported only when containing it exceeding the permissible value.

6. Revision

According to new environmental pollution data, scientific information, legal regulation’s movement, or social changes, this standard shall be revised.

3.3. Procedure for Environmentally Hazardous Substance Survey

1. Purpose

It is intended to reduce environmental load of the company's products and environmental load produced by our production activities by specifying inclusion of environmentally hazardous substances, and utilizing the result thereof, through making clear the survey procedure in performing the environmentally hazardous substance inclusion survey based on the "Green Procurement Standards".

2. Survey Objects

The survey objects shall be raw materials, parts (generally purchased items and supplier processed parts), packaging materials, consumable materials, auxiliary agents, factory controlling members procured by the company, and part of the production facilities, jigs and tools specified of the survey.

3. Methods of Survey Reporting

3.1. Reporting Form

Please answer by the content that asks for the report from the person in charge of our company. Explanations are given on the following cases:

If the response with the following content is difficult, please contact the person in charge of survey.

- 1) A case where items constitute part of the company's products:

Example: Raw materials, parts (generally purchased items and supplier processed parts), packaging materials, and auxiliary agents

Upon inputting the required items by using the "Collective Registration Tool"(Appendix 7). And the document that guarantees the survey content is necessary.

"Collective Registration Tool" has two version, "for electric" and "for automotive". We will request which you use from our company at each investigation request. It is necessary to fill in all the composition materials in case of automotive.

Upon inputting the required items by using the "Collective Registration Tool", submit the report by using the "Environmentally Hazardous Substance Inclusion Report (serving also as guarantee on non-use of substances prohibited of use)" (Appendix 8);, also serving as Guarantee on non-use of substances prohibited of use" (hereinafter the survey report). Since this form serves also as the Guarantee on non-use of substances prohibited of use, the guarantee letter on non-use needs not be submitted separately unless otherwise required.

The above survey report is produced automatically from the collective registration tool. The suppliers will enter the name of the person responsible for the survey and put the company seal. And submit it and "Collective Registration Tool"(excel file) .

- 2) For chemically formed products remaining in the products or constituting part thereof, please follow the procedure in (1) above, and be sure to submit "Component Tables" at the same time.

- 3) Chemically formed products used in the ALPS manufacturing processes, but not remaining in the products, and consumed only in the processes.

Example: Detergent, abrasive, etching solution, surfactant, electric discharge processing oil, resist, releasing solution, developing solution, and chemically formed products for facility maintenance and management.

Please submit MSDS. Basically, no entry is necessary into the above “Appendix 7: Collective Registration Tool”, and the “Appendix 8: Survey Report”. However, we ask for submitting if necessary occasionally.

3.2. Data entry Contents

Explanations are given hereunder on the contents necessary to enter data on environmentally hazardous substances into the collective registration tool.

For the entry method and rules for collective registration tool, please refer to "Operation Manual for Green Procurement Collective Registration Tool".

Please download from the green procurement system the manual of operation. Or, it can be seen also on the " Collective Registration Tool"(Appendix 7).

- 1) Entry of your company’s information

Your company name: Enter your company name as well as names of operation points as required.

Name of persons in charge: Enter the names of persons in charge of the survey.

Tel and e-mail: Enter those of the persons in charge of the survey.

- 2) Parts number

ALPS parts number: Will be specified by us. Numbers may be requested by separate sheets and electronic mails. In such a case, please transfer the entry.

If our company’s parts number is not available, we will request by using your company’s parts number.

Supplier parts number: Enter your company’s parts number.

ALPS parts name: Enter the name of the applicable parts number.

Product mass: Enter mass of the survey object items in the survey unit. In case of individual part, state the mass of one piece. For items not having specific shape, plates and sheets, state the unit mass **per 0.001g**.

For unclear points, please inquire at the window office.

- 3) Methods for surveying contained hazardous substances

- (1) Environmentally hazardous substances being object of the survey: The survey objects are the substances stated in the “List of Environmentally Hazardous Substance (Group)”(Appendix 3).

- (2) Divide the object to be surveyed in those positions and survey whether the environmentally hazardous substance shown in (1) above is contained in each position after describing every

position. For the position that does not contain the contained hazardous substances, enter "environmentally hazardous substance is not contained".

(3) Inclusion position

The position in the column of material constituting information in the collective registration tool corresponds to the inclusion position. For the position in the item of chemical substance inclusion survey, enter the same contents.

The minimum unit constituting the survey objects is called a position. The position indicates the minimum constituting homogeneous section of the particular object. For this purpose, the term "homogeneous" means of "uniform composition throughout." The following do not admit it is homogeneous.

The parts are the same kind of resin being different in color.

The parts are the same kind of resin be contained flame retardant or not.

The parts are the same kind of resin be contained the filler or not.

For the notation of the positions, enter the name of the position and the constituting material in parentheses, such as gear (nylon), lead (tin plate copper wire), and retaining plate (zinc plated steel plate).

Positions not containing the contained need not be stated.

For examples of conception of the position, refer to the "(Reference): How to consider positions to be constitution unit of parts".

(4) Mass of position

The mass in the column of material constituting information in the collective registration tool corresponds to the mass.

For the positions having different shapes made of material of the same composition as described above, state the summed-up mass.

Enter every position of part to be surveyed and bring the product mass in line with the total mass of position.

For paints, state as the position mass the state of paint deposited on the parts, or in other words, the state that solvent has been vaporized and solidified. If the survey object is the paint itself, please understand that the state including everything is naturally the base of the calculation.

When the investigation object is the chemically formed product, it becomes a value that all the constituent materials added up.

(5) Inclusion: Substances included intentionally are the object. Impurities are not included.

When impurities that exceed the inclusion tolerance with the material that sets the inclusion tolerance are contained, it becomes a report object.

(6) Environmentally hazardous substance

State the name and the CAS number. State the name and the CAS number by referring to "Detailed List of Environmentally Hazardous Substances"(Appendix 5). Statement shall be made by using chemical substance name specified by the CAS number in principle.

However, if answering is possible only with substance group due to confidentiality and other reasons, state the control number corresponding to the substance group.

For the substances not stated in “List of Environmentally Hazardous Substance Control Standard”(Appendix 4), state the control number corresponding to the substance group.

If the same substance is contained in plurality of positions, state them by each position.

Fill in the CAS number and substance name if it is clear them but the description not to exist in the “Detailed List of Environmentally Hazardous Substances”(Appendix5).

(7) Content amount

Enter content amount of the environmentally hazardous substance by each position in the mg unit using two effective digits (round third decimals to two decimal places).

Although the item of content amount is made possible of answering by content ratio, please do not answer using the content ratio.

Example: In case of 2549.0 mg, answer is 2500 mg.

In case of 1.1456 mg, answer is 1.1 mg.

In case of 0.00214 mg, answer is 0.0021 mg.

In case of 0.1 mg, answer is 0.1 mg.

In calculating the content amount, any of measured value, theoretical value or design value may be used. If the value has a range, use the maximum value. However, for cadmium and lead in the position of resin, and cadmium, lead, mercury and hexivalent chromium in the packaging material, enter the measured value (analytical value).

* In case of metallic compound, do not execute metal conversion, but answer in the content amount of metallic compound.

In case of alloy, answer in the mass of constituting metals.

Example 1: For the mass when containing antimony trichloride ($SbCl_3$) of 100 mg, enter the amount of antimony trichloride of 100 mg as it is.

Example 2: In case of eutectic solder, answer the amount of lead in the solder, rather than the amount of solder. If answering is possible only with the substance group as described above, and in case of metallic compound group, enter the metal conversion value. Especially for cadmium, mercury, lead, and hexivalent chromium, be sure to enter values using the metal conversion value. This item is indispensable when determining observance of laws.

(8) Purpose

State the purpose for containing the particular substance.

Example 1): Stabilizer, plasticizer, coloring agent, flame retardant, corrosion inhibitor, and solder component

Example 2): Main component, enhancement of thermal stability, enhancement of electrical properties, and enhancement of mechanical properties

Example 3): Impurity (when it is made clear that inclusion is not intentional.)

(9) If the survey object substances are in plurality, enter them similarly by dividing the column.

If the number of statement columns is insufficient, add lines for statement.

(10) Environmentally hazardous substances without statements are judged to have no inclusion.

(11) Cautions for survey

Since the following parts may often contain the environmentally hazardous substances, please make thorough confirmation:

- Lubricants including grease used in parts having moving parts such as bearings and levers.
- Flame retardants in resin materials.
- Vinyl polychloride, flame retardant and stabilizer in lead wire cover.
- Special metals (alloys) intended for electrical lubrication of contact.
- Additives for rubber parts such as belt, roller, bush, and tube.
- Indication paint in color cord.

3.3. Collection of Survey Report and Data

- (1) Since this report also serves as the guarantee for non-use of substances prohibited of use, please pay attention that this report itself cannot be submitted, and the applicable products cannot be delivered if the prohibited substances are contained.
- (2) Upon confirming the output result, enter the name of the responsible person, put the company seal (division seal), and submit it to the department requesting the inclusion survey.
- (3) Please send back the “Collective Registration Tool” file to our person in charge.

(Reference) Conception on Position Being Part Constituting Unit (For electric)

[Example of content amount calculation]; Electrolytic capacitor

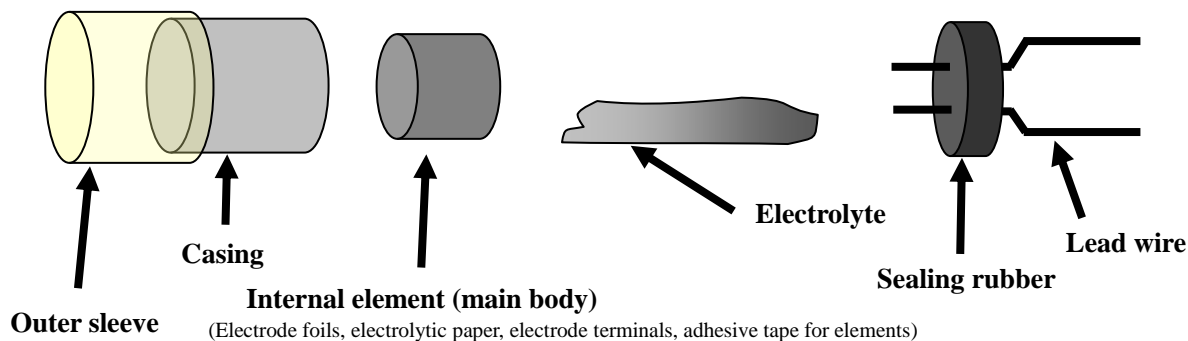

Content amount (example) by each constituting part and its calculation

Chemical substance inclusion data		Substance name	Content amount	Content purpose
Aluminum electrolytic capacitor			1.256 g	
Outer Sleeve(PVC)	0.300 g	poly(vinyl chloride)	150.000 mg	Main material
		diethylhexyl phthalate (DEHP)	120.000 mg	Plasticizer
		antimony trioxide	30.000 mg	Flame retardant
Casing	0.400 g	aluminum	399.400 mg	Main material
		copper	0.500 mg	Impurities
		other metal	0.100 mg	Impurities
Internal Element(Body)				
Electrode foils	0.210 g	aluminum	100.000 mg	Main material (Base resin)
		aluminium oxide	10.000 mg	Main material (Dielectric substance)
		aluminum	100.000 mg	Main material
Electrolytic paper	0.110 g	copper	0.200 mg	Impurities
		cellulose	100.000 mg	Main material
		other additives	10.000 mg	Stabilizer
Electrode terminals	0.004 g	aluminum	4.000 mg	Main material
		copper	0.080 mg	Impurities
Adhesive tape for elements	0.002 g	polypropylene	1.000 mg	Main material
		Acrylic copolymer	0.400 mg	Main material
		ethyl acetate	0.400 mg	Main ingredients
		toluene	0.100 mg	Main ingredients
		hexane	0.090 mg	Main ingredients
		butan-1-yl acrylate	0.009 mg	Softening agent
		diethyl phthalate	0.001 mg	Softening agent
Electrolyte	0.110 g	ethylene glycol	80.000 mg	Main ingredients(solvent)
		adipic acid, ammonium salt	20.000 mg	Main ingredients(solute)
		boric acid	0.100 mg	Stabilizer
		other additives	9.900 mg	Stabilizer
Sealing rubber	0.100 g	nitrile-butadiene rubber	50.000 mg	Main ingredients
		carbon black	25.000 mg	Improvement in mechanical performance
		silica	10.000 mg	Improvement in mechanical performance
		diethylhexyl phthalate (DEHP)	8.000 mg	Softening agent
		other additives	7.000 mg	Improvement in mechanical performance
Lead wire	0.020 g	copper	19.980 mg	Main ingredients
		tin	0.019 mg	Main ingredients

The answer will be as follows: (For Automotive)

Structure Parts Information				Chemical Substance Inclusion Data					
Parts Name	Material Name	Mass	Unit	CAS No.	Substance Name	Content Amount /Rate	Unit	Purpose of Inclusion	JAMA Content purpose
Outer Sleeve(PVC)	poly(vinyl chloride)	0.3	g	9002-86-2	poly(vinyl chloride)	150.000	mg	Main material	Main component
				117-81-7	diethylhexyl phthalate (DEHP)	120.000	mg	Plasticizer	Machining
				1309-64-4	antimony trioxide	30.000	mg	Flame retardant	Flame resistance
Casing	aluminum	0.4	g	7429-90-5	aluminum	399.400	mg	Main material	Main component
				7440-50-8	copper	0.500	mg	Impurities	Impurity(unintentional presence)
				AL99	other metal	0.100	mg	Impurities	Impurity(unintentional presence)
Internal Element(Body)	anode foil	0.2102	g	7429-90-5	aluminum	100.000	mg	Main material (Base resin)	Main component
				1344-28-1	aluminium oxide	10.000	mg	Main material (Dielectric substance)	Main component
				7429-90-5	aluminum	100.000	mg	Main material	Main component
				7440-50-8	copper	0.200	mg	Impurities	Impurity(unintentional presence)
				9004-34-6	cellulose	100.000	mg	Main material	Main component
				AL99	other additives	10.000	mg	Stabilizer	Thermal stability
Internal terminals	0.00408	g	7429-90-5	aluminum	4.000	mg	Main material	Main component	
				7440-50-8	copper	0.080	mg	Impurities	Impurity(unintentional presence)
Adhesive tape for elements	0.002	g	25085-53-4	1-Propene, homopolymer, isotactic	1.000	mg	Main material	Main component	
				26760-85-0	2-Propenoic acid, butyl ester, polymer with 2-ethylhexyl 2-propenoate	0.400	mg	Main material	Main component
				141-78-6	ethyl acetate	0.400	mg	Main ingredients	Main component
				108-88-3	toluene	0.100	mg	Main ingredients	Main component
				110-54-3	hexane	0.090	mg	Main ingredients	Main component
				141-32-2	butan-1-yl acrylate	0.009	mg	Softening agent	Machining
				84-66-2	diethyl phthalate	0.001	mg	Softening agent	Machining
Eelectrolyte	0.11	g	107-21-1	ethylene glycol	80.000	mg	Main ingredients(solvent)	Main component	
				19090-60-9	adipic acid, ammonium salt	20.000	mg	Main ingredients(solute)	Main component
				10043-35-3	boric acid	0.100	mg	Stabilizer	Thermal stability
				AL99	other additives	9.900	mg	Stabilizer	Thermal stability
Ssealing rubber	0.1	g	AL88	nitrile-butadiene rubber	50.000	mg	Main ingredients	Main component	
				1333-86-4	carbon black	25.000	mg	Improvement in mechanical performance	Mechanical property
				14808-60-7	silica	10.000	mg	Improvement in mechanical performance	Mechanical property
				117-81-7	diethylhexyl phthalate (DEHP)	8.000	mg	Softening agent	Machining
				AL99	other additives	7.000	mg	Improvement in mechanical performance	Mechanical property
Lead wire	0.019999	g	7440-50-8	copper	19.980	mg	Main ingredients	Main component	
			7440-31-5	tin	0.019	mg	Main ingredients	Main component	

Example: Environmentally Hazardous Substance Inclusion Report (For Automotive)

Environmentally Hazardous Substa

Abbreviation: Inclusion
 Date of submittal:)
 Day Month Year
 Company name
 Responsible person
 TEL
 FAX
 E-MAIL

Image

Investigation request No.

enduse gas (such as PFC), *Chloroform, *Reproductive toxicity substances
 yde organ: chlorinated solvent (such as dichloromethane), *Substance Chart
 ds, *Mercury and its compounds, *Specific brominated flame retardants
 apounds,
 uids (triglycyl tributyl tin), *Hexavalent chromium compounds, *Azo dye, *Tel
 unium in packaging materials, *Radioactive Substances, *Arsenic and its
 its related substances, *Dimethyltinazane, *Volatile organic compounds
 acyclic 1, 1, 1, 3, 3, 3-hexa-1H-cyclohexylpentane, *Silver, *Chlorinated flame
 (with lead oxide (pb) and triethanolamine pentachloric acid, mercury(2+)
 *Phenylendianiline and its salt, *Vinyl chloride, *Monomer

Receipt

The products delivered hazardous substances among those specified by Alps Electric Company.
 The environmentally hazardous substances not stated herein are not contained.
 It is guaranteed that prohibited substances described below are not contained.

(a8) Phenol, 2-(2H-benzotriazol-2-yl)-4,6-bis(1,1-dimethylethyl)-
 For details, refer to the Green Procurement Standard

(Returns for Alps company reserved)

ALPS parts number	Supplier product number	Supplier product name	Product mass (g)	Parts(Material Name)	Parts mass (g)	Package insert number	Substance name	CAS No	JAMA Content purpose	Content amount (mg)	Content rate (ppm)	Applied
XXXXXXNONE	EXAMPLE	Aluminum electrolytic capacitor	1.256279	Sleeve(PVC/poly(vinyl chloride))	0.3		poly(vinyl chloride)	9002-96-5	Main component	150	500000	133C
							bis(2-ethylhexam-1-yl) phthalate / di(2-ethylhexyl)phthalate (DEHP)	117-61-7	Machining	120	400000	134A
							antimony trioxide	1309-64-4	Flame resistance	30	100000	125C
				Case(Aluminum)	0.4		aluminum	7429-90-5	Main component	400	1000000	0000E
							copper (metallic)	7440-50-8	Impurity(unintentional presence)	0.5	1300	163C
							The other substances which do not contain a regulation substance.	AL59	Impurity(unintentional presence)	0.1	250	099D
				Internal Element(Body/Electrode foil)	0.2102		aluminum	7429-90-5	Main component	100	480000	0000E
							aluminum oxide	1344-28-1	Main component	10	48000	0000E
							aluminum	7429-90-5	Main component	100	480000	0000E
							copper (metallic)	7440-50-8	Impurity(unintentional presence)	0.2	950	163C
				Internal Element(Body/Electrolytic paper)	0.11		cellulose	9004-34-6	Main component	100	910000	0000E
							The other substances which do not contain a regulation substance.	AL59	Thermal stability	10	91000	099D
				Internal Element(Body/Electrode terminals)	0.00408		aluminum	7429-90-5	Main component	4	980000	0000E
							copper (metallic)	7440-50-8	Impurity(unintentional presence)	0.08	20000	163C
				Internal Element(Body/Adhesive tape for elements)	0.002		1-Propene, homopolymer, isotactic	25085-53-4	Main component	1	500000	0000E
							2-Propenoic acid, butyl ester, polymer with 2-ethylhexyl 2-propenoate	26760-85-0	Main component	0.4	200000	0000E
							ethyl acetate	141-79-6	Main component	0.4	200000	148C

[Example 1 for conception of constituting position] Connectors

Constituting position: Housing, contact

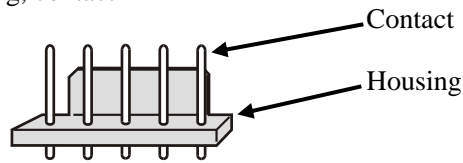

[Example 2 for conception of constituting position] Parts having mechanism part, such as switch and relay

Constituting position: Parts case (resin molded), metallic parts (lever, frame, lead terminal), movable part (contact)

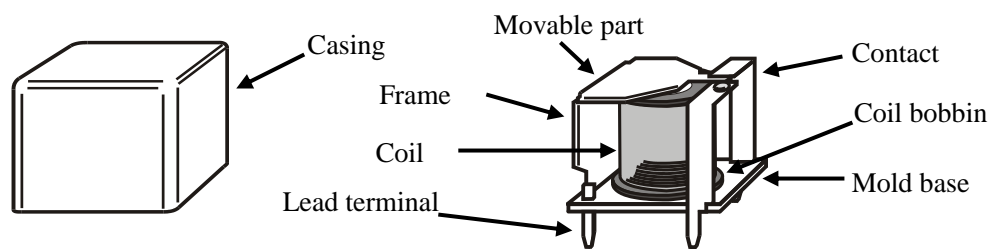

*Pay attention to flame retardant in resin, and special metals (alloys) intended of electrical properties and lubrication of contact.

[Example 3 for conception of constituting position] Surface mounted type chip parts

Constituting position: Terminal part, main body of part

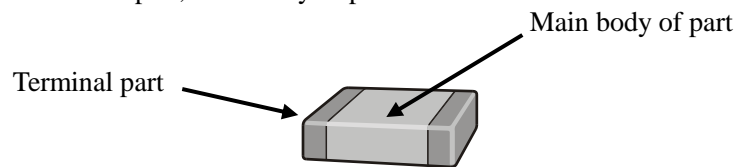

[Example 4 for conception of constituting position] Semiconductor device

Constituting position: Lead terminal (lead frame), main package body (molded resin), device chip

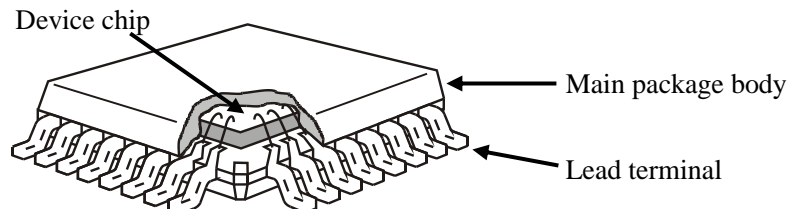

* Pay attention to flame retardant in package resin material, and material and treatment of lead.

[Example 5 for conception of constituting position] Transformer, inductors

Constituting position: Core, winding, bobbin, lead wire, lead wire cover, insulator, case frame

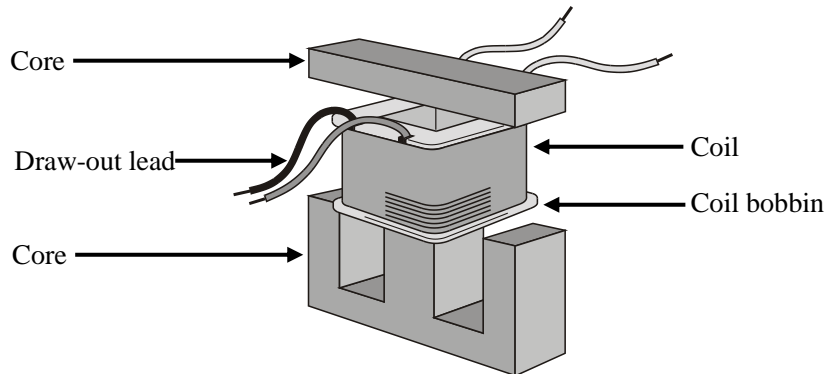

* Pay attention to resin material, flame retardant in insulating parts, impregnant in coil, PVC and flame retardant in lead wire cover.

[Example 6 for conception of constituting position] DC motor

Constituting position: Parts case (resin molded), sintered bearing, impregnation oil, shaft, brush, rotor core, magnet, winding, brush, resin case

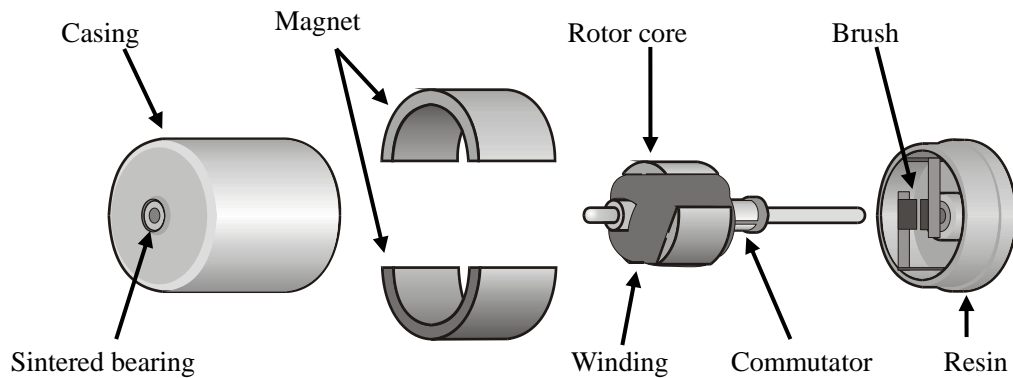

*Pay attention to flame retardant in resin, special metals (alloys) intended of electrical properties and lubrication of commutator, and grease in sintered bearing. Calculate content amounts in respective positions, such as the case including lead wire and electronic circuit.

Note: Part of the “(Reference) Conception on position being part constituting unit” was quoted from the “Manual for survey on chemical substances contained in parts and materials” prepared by the council to make common the Green Procurement survey.

アルプスグループ環境憲章

基本理念

アルプスは地球社会の一員として、社会の持続可能な発展のため、卓越した技術に支えられた事業活動とし社員行動を通じて、美しい自然を守り、貴重な資源を大切にします。

行動指針

私たちはいつも環境保全に心掛け

1. 環境を意識した製品開発に取り組めます
2. 環境にやさしい生産・販売に取り組めます
3. モノを大切にします
4. ムダを省きます
5. リサイクルに努めます

The Alps Group Environmental Charter

Basic Philosophy

Alps, as a member of the global community, is committed to protecting the beauty of nature and to safeguarding our precious resources through the use of technologically advanced business practices and the efforts of its employees, in order to promote sustainable development.

Action Program

Placing priority on environmental preservation, we at Alps will:

1. Develop products in light of environmental concerns
2. Engage in environmentally friendly production and sales
3. Conserve our natural resources
4. Reduce or eliminate waste
5. Increase recycling activities